



Premium Quality



Environmentally Friendly



Towing^

S410

Contender Spring Loaded Kingpinless Casters

CAPACITY TO 3000



Designed from high quality, heat treated AISI 1045 stamped steel. Zinc plating delivers greater corrosion resistance than paint. Inside and outside welds deliver superior strength.

Greater capacity and better shock protection. Noise levels are reduced through the dampening effect of these casters.

Capacities listed at 50% of wheel deflection (21/32"). Total wheel deflection is 1-5/16".

TYPICAL APPLICATIONS

- Conveyor-drawn tow-trucks
- Heavy duty bakery racks
- Production dollies
- Heavy duty dough troughs
- Aviation Ground Support
- Aircraft Tripod Jacks
- Shock Sensitive Loads

SWIVEL CROSS SECTION

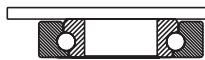

MOUNTING OPTIONS

Standard Plate

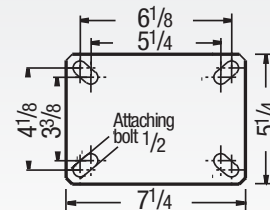

Special Order Plates

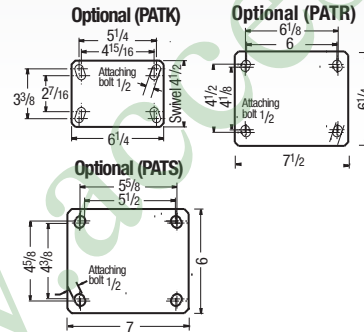

FEATURES

- **Load Springs:** Protect from damaging shocks and reduce noise levels through the dampening effect of the springs
- **Top Plate:** 3/8" AISI 1045 heat treated steel welded inside and out for longer life
- **Swivel Section:** One row of 1/2" ball bearings mounted in a heat treated precision machined raceway. Zerk in swivel section.
- **Yoke Base:** Notched AISI 1045 heat treated steel
- **Legs:** welded inside and out
- **Axle:** 3/4" diameter
- **Finish:** Zinc plating
- Alternate or custom caster configurations available

RIG OPTIONS

- For non-spring loaded versions, see 410 Series on pages 50-51
- S410 optional plates also available; consult factory

BRAKE OPTIONS

Consult factory

+ For swivel models add "S", for rigid model add "R" to end of base caster number.

Mold-on Polyurethane on Aluminum (01 Roller Bearing)*

PD	Wheel Diameter (Inches)	Tread Width (Inches)	Capacity (Lbs) (Rate for manual operation)	Overall Height (Inches)	Swivel Lead (Inches)	Base Caster Number+
8	2 1/2	2010	117/8	47/8		S410PD08401
8	3	2520	117/8	47/8		S410PD08501
10	2 1/2	2370	14	47/8		S410PD10401
10	3	3000	14	47/8		S410PD10501

Standard durometer 60 Shore D. Other durometers available.

*Tapered Roller (09) bearings available. To order change "01" to "09". Example: S410PD10409.

Polyurethane on Cast Iron (09 Tapered Roller Bearing)*

PY	Wheel Diameter (Inches)	Tread Width (Inches)	Capacity (Lbs) (Rate for manual operation)	Overall Height (Inches)	Swivel Lead (Inches)	Base Caster Number+
6	2 1/2	1600	107/8	47/8		S410PY06409
6	3	2000	107/8	47/8		S410PY06509
8	2 1/2	2000	117/8	47/8		S410PY08409
8	3	2500	117/8	47/8		S410PY08509
10	2 1/2	2300	14	47/8		S410PY10409
10	3	3000	14	47/8		S410PY10509
12	2 1/2	2700	16	5 11/16		S410PY12409
12	3	3000	16	5 11/16		S410PY12509

*Roller (01) bearings available. To order change "09" to "01".

Example: S410PY10401.

PY 80A

80 Shore A



80A Durometer available, add "80A" to end of caster number.

80A capacity reduced by approximately 20%.

Swivel example: S410PY06409S80A.

For 70D consult factory.

Moldon Rubber on Cast Iron (09 Tapered Roller Bearing)*

MR/MH	Wheel Diameter (Inches)	Tread Width (Inches)	Capacity (Lbs) (Rate for manual operation)	Overall Height (Inches)	Swivel Lead (Inches)	Base Caster Number+
6	2 1/2	700	107/8	47/8		S410MR06409
6	3	750	107/8	47/8		S410MR06509
8	2 1/2	850	117/8	47/8		S410MR08409
8	3	900	117/8	47/8		S410MR08509
10	2 1/2	950	14	47/8		S410MR10409
10	2 1/2**	1500	14	47/8		S410MH10409
10	3	1000	14	47/8		S410MR10509
10	3**	1800	14	47/8		S410MH10509
12	2 1/2	950	16	5 11/16		S410MR12409
12	2 1/2**	1700	16	5 11/16		S410MH12409
12	3	1200	16	5 11/16		S410MR12509

*Roller (01) bearings available. To order change "09" to "01".

Example: S410MR10401.

**Heavy-duty MH version of wheel.

Thick Tread Polyurethane (09 Tapered Roller Bearing)*

PX	Wheel Diameter (Inches)	Tread Width (Inches)	Capacity (Lbs) (Rate for manual operation)	Overall Height (Inches)	Swivel Lead (Inches)	Base Caster Number+
6	3	2250	107/8	47/8		S410PX06509
8	3	2780	117/8	47/8		S410PX08509
10	2 1/2	2600	14	47/8		S410PX10409
10	3	3000	14	47/8		S410PX10509
12	3	3000	16	5 11/16		S410PX12509

Standard durometer 95 Shore A. Other durometers available.

*Roller (01) bearings available. To order change "09" to "01".

Example: S410PX10401.

Continue on next page >>

