

Endurance™ Kingpinless-Style Casters



The *Endurance™* Series casters represent the “best of breed” in kingpinless-style design. The top plate and inner raceway are formed from one piece, providing a superior raceway for shock conditions. Once formed, the raceways are CNC-machined and then induction hardened to ensure a uniform depth in hardness of the swivel raceway. A sealing cap is welded to the outer race to assure protection from foreign material and to keep grease in the raceway.

All *Endurance™* Series casters are finished in bright zinc plating and come standard with a choice of ten different wheel types. Standard bearing selections include double sealed precision ball bearings, precision tapered bearings, or straight roller bearings.

QUALITY FEATURES

Swivel Construction – forged steel top plate and fork base; 1/4" x 2" plate steel legs on 2" wheel widths and 5/16" x 2 1/2" plate steel legs on 3" wheel widths. Legs welded inside and outside to forged steel horn base. Finished in bright zinc plate.

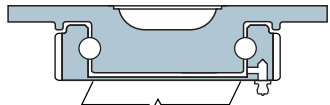

Load Bearing – Induction hardened and CNC-machined raceway; 2 3/8" swivel diameter with 3/8" balls in 2" wheel widths and 3" diameter raceway with 1/2" balls in 3" wide wheels.

Axle – 1/2" diameter hex head with lock nut in 2" wheel widths or 3/4" diameter in 3" wheel widths.

Lubrication Fittings – ball-check type in swivel assembly and wheel hub.



#S-EC-82AYB Swivel showing Polylast™ wheel

#R-EC-83FST Rigid model showing Forged Steel Wheel



OPTIONAL ACCESSORIES *more help on page 13*

- **Swivel Lock – 4 position field installable (★-4SL)**
– convert swivel to rigid for straight line steering
- **Wheel Bearing Seals (-BS/-DS)**
– prolongs wheel life in harsh environments

FEATURED WHEEL BEARINGS



BRAKE CHOICES *for more help, see page 20*

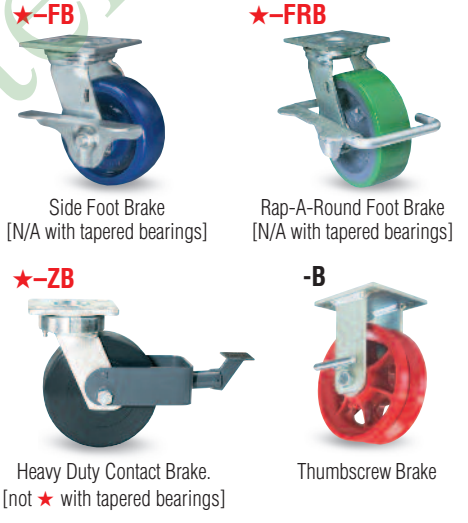

★ = same day/next day **PRONTO®** shipment.

EC Series Selection Table Part 1 of 2

3YR = 3 Year Warranty applies

Dia. A	Wheel			Swivel Caster			Rigid Caster			Load Cap. Lbs.	Overall Height B	Swivel Offset G	Mounting Plate		
	Face	Type	Replacement Number	Hamilton No. Roller/Prec. BB	Hamilton No. Tapered Brgs.	Wt. Lbs.	Hamilton No. Roller/Prec. BB	Hamilton No. Tapered Brgs.	Wt. Lbs.				Size C & D	Holes E & F	Bolt Size
4	1 1/2	Forged Steel	W-415-FS-3/4	★S-EC-4FS 3YR	X	9	★R-EC-4FS 3YR	X	8	1400	5%	1 3/16	4 x 4 1/2	2% x 3% slotted to 3 x 3	3/8
		Duralast®	W-420-DB-1/2	★S-EC-4DB 3YR	X	9	★R-EC-4DB 3YR	X	7	750					
		Duralast®XC	W-420-DB70-1/2	★S-EC-4DB70 3YR	X	9	★R-EC-4DB70 3YR	X	7	975					
		Metal	W-420-MB-1/2	★S-EC-4MB	X	8	★R-EC-4MB	X	6	1000					
		Nylast™†	W-420-NYB-1/2	★S-EC-4NYB	X	6	★R-EC-4NYB	X	5	2000					
		Plastex*	W-420-P-3/4	★S-EC-4P	X	6	★R-EC-4P	X	5	800					
		Polylast™	W-422-AYB-1/2	★S-EC-42AYB	X	9	★R-EC-42AYB	X	7	300					
		Poly-Soft®	W-420-SPB-1/2	★S-EC-4SPB 3YR	X	9	★R-EC-4SPB 3YR	X	7	600					
		Swivel-EAZ™	W-420-SWF-1/2	★S-EC-4SWF 3YR	X	12	★R-EC-4SWF 3YR	X	9	875					
UltraLast™	W-420-TRB-1/2	S-EC-4TRB 3YR	X	9	R-EC-4TRB 3YR	X	7	900							
5	2	Duralast®	W-520-DB-1/2	★S-EC-5DB 3YR	★S-EC-5DT 3YR	10	★R-EC-5DB 3YR	★R-EC-5DT 3YR	8	1050	6 1/2	1%	4 x 4 1/2	2% x 3% slotted to 3 x 3	3/8
		Duralast®XC	W-520-DB70-1/2	★S-EC-5DB70 3YR	S-EC-5DT70 3YR	10	★R-EC-5DB70 3YR	R-EC-5DT70 3YR	8	1360					
		Forged Steel	W-5-FS-3/4	★S-EC-5FS	S-EC-5FST 3YR	10	★R-EC-5FS	R-EC-5FST 3YR	9	1500					
		Metal	W-520-MB-1/2	★S-EC-5MB	X	10	★R-EC-5MB	X	8	1300					
		Plastex	W-520-P-3/4	★S-EC-5P	X	7	★R-EC-5P	X	5	1000					
		Poly-Soft®	W-520-SPB-1/2	★S-EC-5SPB 3YR	★S-EC-5SPT 3YR	9	★R-EC-5SPB 3YR	★R-EC-5SPT 3YR	8	840					
		UltraLast™	W-520-TRB-1/2	S-EC-5TRB 3YR	S-EC-5TRT 3YR	10	R-EC-5TRB 3YR	R-EC-5TRT 3YR	8	1250					

WHEEL CHOICES for more help, see pages 14 & 15



Duralast®:
95A poly on iron – our standard urethane



Duralast® XC:
70D poly on iron – extra capacity, harder urethane



Forged Steel:
highest capacity, tensile strength 75,000 psi



Metal:
cast iron, heavy duty design



Nylast™:
high capacity cast nylon, corrosion resistant



Plastex:
phenolic, low cost, high capacity



Polylast™:
Donut Tread 85A Poly on Aluminum Core



Poly-Soft®:
85A softer poly on iron – quieter, easy rolling, debris resistant urethane



Swivel-EAZ®:
Twin Wheel Poly on Aluminum, easy turning



Ultralast™:
95A – the ultimate premium urethane, out-performs all other urethanes

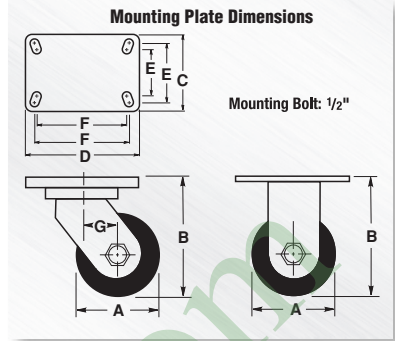

★ = same day/next day **PRONTO®** shipment.

EC Series Selection Table Part 2 of 2

3YR = 3 Year Warranty applies

Dia. A	Wheel		Swivel Caster			Rigid Caster			Load Cap. Lbs.	Overall Height B	Swivel Offset G	Mounting Plate			
	Face	Type	Replacement Number □	Hamilton No. † Roller/Prec. BB	Hamilton No. † Tapered Brgs.	Wt. Lbs.	Hamilton No. † Roller/Prec. BB	Hamilton No. † Tapered Brgs.				Wt. Lbs.	Size C x D	Holes E & F	Bolt Size
6	2	Duralast®	W-620-DB-½	★ S-EC-6DB 3YR	★ S-EC-6DT 3YR	11	★ R-EC-6DB 3YR	★ R-EC-6DT 3YR	10	1200	7½	1⅞	4 x 4½	2⅞ x 3⅞ slotted to 3 x 3	⅜
		Duralast®XC	W-620-DB70-½	★ S-EC-6DB70 3YR	S-EC-6DT70 3YR	11	★ R-EC-6DB70 3YR	R-EC-6DT70 3YR	10	1560					
		Forged Steel	W-620-FS-¾	★ S-EC-6FS 3YR	S-EC-6FST 3YR	13	★ R-EC-6FS 3YR	R-EC-6FST 3YR	11	2000					
		Metal	W-620-MB-½	★ S-EC-6MB	X	11	★ R-EC-6MB	X	10	1400					
		Nylast™ ‡	W-620-NYB-½	★ S-ES-6NYB	X	12	★ R-EC-6NYB	X	10	2000					
		Plastex	W-620-P-¾	★ S-EC-6P	X	8	★ R-EC-6P	X	7	1200					
	3	Polylast™	W-622-AYB-½	★ S-EC-62AYB 3YR	X	10	★ R-EC-62AYB 3YR	X	8	600					
		Poly-Soft®	W-620-SPB-½	★ S-EC-6SPB 3YR	S-EC-6SPT 3YR	11	★ R-EC-6SPB 3YR	R-EC-6SPT 3YR	10	960					
		Swivel-EAZ™	W-620-SWF-½	★ S-EC-6SWF 3YR	X	12	★ R-EC-6SWF 3YR	X	9	1400					
		Ultralast™	W-620-TRB-½	★ S-EC-6TRB 3YR	S-EC-6TRT 3YR	11	★ R-EC-6TRB 3YR	R-EC-6TRT 3YR	10	1200					
		Duralast®	W-630-DB-¾	★ S-EC-63DB 3YR	★ S-EC-63DT 3YR	19	★ R-EC-63DB 3YR	★ R-EC-63DT 3YR	16	2200					
		Duralast®XC	W-630-DB70-¾	★ S-EC-63DB70 3YR	S-EC-63DT70 3YR	19	★ R-EC-63DB70 3YR	R-EC-63DT70 3YR	16	2860					
8	2	Forged Steel	W-630-FSB-¾	★ S-EC-63FSB 3YR	★ S-EC-63FST 3YR	27	★ R-EC-63FSB 3YR	★ R-EC-63FST 3YR	24	3000	9½	2½	4½ x 6¼	2⅞ x 4⅞ slotted to 3⅞ x 5¼	½
		Metal	W-630-MB-¾	★ S-EC-63MB	S-EC-63MT	19	★ R-EC-63MB	R-EC-63MT	16	2500					
		Nylast™ ‡	W-630-NYB-¾	★ S-ES-63NYB	X	18	★ R-EC-63NYB	X	16	3000					
		Plastex ‡*	W-630-P-1	★ S-EC-63P	S-EC-63PT	17	★ R-EC-63P	R-EC-63PT	14	2000					
	3	Poly-Soft®	W-630-SPB-¾	★ S-EC-63SPB 3YR	S-EC-63SPT 3YR	19	★ R-EC-63SPB 3YR	R-EC-63SPT 3YR	16	1800					
		Ultralast™	W-630-TRB-¾	★ S-EC-63TRB 3YR	S-EC-63TRT 3YR	19	★ R-EC-63TRB 3YR	R-EC-63TRT 3YR	16	2600					
		Duralast®	W-820-DB-½	★ S-EC-8DB 3YR	★ S-EC-8DT 3YR	14	★ R-EC-8DB 3YR	★ R-EC-8DT 3YR	13	1500					
		Duralast®XC	W-820-DB70-½	★ S-EC-8DB70 3YR	S-EC-8DT70 3YR	14	★ R-EC-8DB70 3YR	R-EC-8DB70 3YR	12	1950					
10	2	Metal	W-820-MB-½	★ S-EC-8MB	X	13	★ R-EC-8MB	X	12	1500	10½	2	4 x 4½	2⅞ x 3⅞ slotted to 3 x 3	⅜
		Nylast™ ‡	W-820-NYB-½	★ S-EC-8NYB	X	14	★ R-EC-8NYB	X	12	2000					
		Plastex	W-820-P-¾	★ S-EC-8P	X	9	★ R-EC-8P	X	8	1400					
		Polylast™	W-822-AYB-½	★ S-EC-82AYB 3YR	X	10	★ R-EC-82AYB 3YR	X	9	1000					
		Poly-Soft®	W-820-SPB-½	★ S-EC-8SPB 3YR	S-EC-8SPT 3YR	14	★ R-EC-8SPB 3YR	R-EC-8SPT 3YR	12	1200					
		Swivel-EAZ™	W-820-SWF-½	★ S-EC-8SWF 3YR	X	14	★ R-EC-8SWF 3YR	X	2000						
	3	Ultralast™	W-820-TRB-½	★ S-EC-8TRB 3YR	S-EC-8TRT 3YR	14	★ R-EC-8TRB 3YR	R-EC-8TRT 3YR	12	1800					
		Duralast®	W-830-DB-¾	★ S-EC-83DB 3YR	★ S-EC-83DT 3YR	25	★ R-EC-83DB 3YR	★ R-EC-83DT 3YR	22	2500					
		Duralast®XC	W-830-DB70-¾	★ S-EC-83DB70 3YR	S-EC-83DT70 3YR	25	★ R-EC-83DB70 3YR	R-EC-83DB70 3YR	22	3000					
		Forged Steel	W-830-FSB-¾	★ S-EC-83FSB 3YR	★ S-EC-83FST 3YR	28	★ R-EC-83FSB 3YR	★ R-EC-83FST 3YR	25	3000					
		Metal	W-830-MB-¾	★ S-EC-83MB	S-EC-83MT	26	★ R-EC-83MB	R-EC-83MT	23	2600					
		Nylast™ ‡	W-830-NYB-¾	★ S-ES-83NYB	X	19	★ R-EC-83NYB	X	17	3000					
3	Plastex ‡*	W-830-P-1	★ S-EC-83P	S-EC-83PT	18	★ R-EC-83P	R-EC-83PT	15	3000						
	Poly-Soft®	W-830-SPB-¾	★ S-EC-83SPB 3YR	S-EC-83SPT 3YR	25	★ R-EC-83SPB 3YR	R-EC-83SPT 3YR	22	2000						
	Ultralast™	W-830-TRB-¾	★ S-EC-83TRB 3YR	S-EC-83TRT 3YR	25	★ R-EC-83TRB 3YR	R-EC-83TRT 3YR	22	3000						
	Duralast®	W-1030-DB-¾	★ S-EC-13DB 3YR	★ S-EC-13DT 3YR	29	★ R-EC-13DB 3YR	★ R-EC-13DT 3YR	26	3000						
	Duralast®XC	W-1030-DB70-¾	★ S-EC-13DB70 3YR	S-EC-13DT70 3YR	29	R-EC-13DB70 3YR	R-EC-13DB70 3YR	26	3000						
	Forged Steel	W-1030-FSB-¾	★ S-EC-13FSB 3YR	★ S-EC-13FST 3YR	36	★ R-EC-13FSB 3YR	★ R-EC-13FST 3YR	33	3000						
3	Metal	W-1030-M-1	★ S-EC-13M	S-EC-13MT	27	★ R-EC-13M	R-EC-13MT	24	2600						
	Plastex	W-1030-P-1	★ S-EC-13P	S-EC-13PT	22	★ R-EC-13P	R-EC-13PT	19	2900						
	Poly-Soft®	W-1030-SPB-¾	★ S-EC-13SPB 3YR	S-EC-13SPT 3YR	29	★ R-EC-13SPB 3YR	R-EC-13SPT 3YR	26	2400						
	Ultralast™	W-1030-TRB-¾	S-EC-13TRB 3YR	S-EC-13TRT 3YR	29	R-EC-13TRB 3YR	R-EC-13TRT 3YR	26	3000						

□ With straight roller or precision ball bearings. For catalog number of corresponding tapered bearing wheels, consult factory.

† Hamilton No.s ending in B = Prec. Ball Bearing, T = Prec. Tapered Roller Bearing, any other letter = Straight Roller Bearing.

* This wheel lubricated through lube axle. ‡ Straight-sided wheel.