

125 SERIES CASTERS

CASTERS

KINGPINLESS

ENGINEERED TO OUTPERFORM

RWM's 125 Series features the patented Kingpinless™ caster design. This is the design that RWM patented, and that has proven itself to be the best solution for demanding applications. This is the caster design that all others are now copying because it is simply unmatched in extending service life and reducing all possible causes for caster failure. The 125 Series offers capacity up to 40,000 pounds. Typical applications include ground support equipment, die carts, and aircraft engine stands. Leg thickness of 1/2" adds extra strength and durability. All swivel sections are supplied with a lubrication fitting for field maintenance.



125-UIT-0840-S

FEATURES

Raceway Design	Patented Kingpinless™ single ball bearing precision machined raceway hardened to 53 Rockwell C Minimum, 7" diameter raceway with 3/4" diameter ball bearings.
Capacity	Up to 40000 lbs.
Finish	Laguna blue powder coat.
Wheels	Wheels are either 3", 4", 5" or 6" wide depending upon wheel size and type. Wheels have either a 3/4", 1", 1-1/4" or 1-1/2" roller bearing or 3/4", 1", 1-1/4" tapered wheel bearings. Roller bearing wheels rotate on a hardened and ground spanner, tapered wheel bearings rotate on the axle. All wheels are equipped with lubrication fittings.
Mounting Plate Size	8-1/2" x 8-1/2" x 1/2"
Bolt Hole Spacing	7" x 7"
Bolt Hole Spacing	5/8"

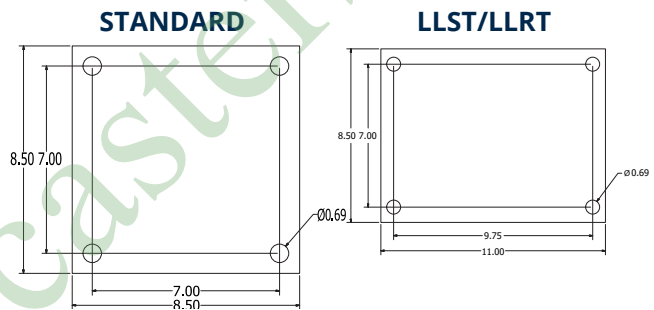

KINGPINLESS RACEWAY

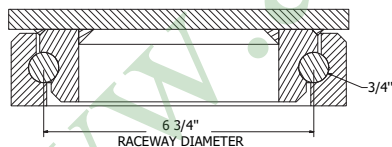

APPLICATIONS

Tow lines	Boat & ship molding and building
Abusive conditions	Storage tanks & gantries
Automotive	Shock load applications
Aerospace	Production line dollies
Metal fabricating	Heavy machinery
Military equipment	Mobile homes
Tractor pulled trailers	Extreme duty platform trucks
Air cargo & ground support equipment	Heavy duty processing equipment

OPTIONS

BRAKES	
FCWB	Face Contact Wheel Brake
PCWB	Poly Cam Wheel Brake
SWIVEL LOCKS	
8 SL	Positional Swivel Lock
DSL	Demountable Swivel Lock
HDSL	Heavy Duty Demountable Swivel Lock
LSL	L-Type Swivel Lock
SL	Swivel Lock
VSL	Vertical Swivel Lock
LUBRICATIONS	
HT	High Temperature Lubrication
LT	Low Temperature Lubrication
FINISHES	
HTP	High Temperature Paint
ZP	Zinc Plated
GUARDS, DISC AND SWEEPERS	
FG	Foot Guard
SR	Sealed Raceway
SWP	Sweeper Brush
WS	Wheel Seals

UP TO 40,000 LBS CAPACITY

Wheel Diameter	Wheel Width	Capacity lbs.	Wheel Type	Overall Height	Swivel Caster Model Numbers		Swivel Lead	Approx Weight lbs.
					Straight Roller Bearing	Tapered Roller Bearing		
8"	4"	3500	Urethane on Iron	11"	125- UIR -0840-S	125- UIT -0840-S	2-3/16"	62
		4000	Cast Iron	11"	125- CIR -0840-S	125- CIT -0840-S	2-3/16"	70
		10000	Forged Steel	11"	125- FSR -0840-S		2-3/16"	86
		10000	V-Grooved Forged	11"	125- VFR -0840-S		2-3/16"	80
		15000	V-Grooved Forged	11"		125-VFT-0840-S	2-3/16"	80
		20000	Forged Steel - HD	11"		125- FST -0840-S	2-3/16"	86
10"	4"	1400	Rubber On Iron	13"	125- RIR -1040-S	125- RIT -1040-S	2-9/16"	72
		4200	Urethane on Iron	13"	125- UIR -1040-S	125- UIT -1040-S	2-9/16"	75
		4500	Ultra Thick Urethane	13"	125- UTR -1040-S	125- UTT -1040-S	2-9/16"	62
		5000	Cast Iron	13"	125- CIR -1040-S	125- CIT -1040-S	2-9/16"	90
		10000	Forged Steel	13"	125- FSR -1040-S		2-9/16"	100
		10000	V-Grooved Forged	13"	125- VFR -1040-S		2-9/16"	92
		15000	V-Grooved Forged	13"		125-VFT-1040-S	2-9/16"	92
20000	Forged Steel - HD	13"		125- FST -1040-S	2-9/16"	100		
10"	5"	5000	Urethane on Iron	13"	125- UIR -1050-S	125- UIT -1050-S	2-9/16"	80
		6000	Cast Iron	13"	125- CIR -1050-S	125- CIT -1050-S	2-9/16"	95
11"	5"	1760	Rubber On Iron	14"	125- RIR -1150-S	125- RIT -1150-S	2-5/8"	85
		5500	Urethane on Iron	14"	125- UIR -1150-S	125- UIT -1150-S	2-5/8"	85
11"	6"	10000	Cast Iron	14"	125- CIR -1160-S	125- CIT -1160-S	2-3/4"	95
12"	4"	1600	Rubber On Iron	15-1/2"	125- RIR -1240-S	125- RIT -1240-S	3-3/8"	78
		4800	Urethane on Iron	15-1/2"	125- UIR -1240-S	125- UIT -1240-S	3-3/8"	78
		5300	Ultra Thick Urethane	15-1/2"	125- UTR -1240-S	125- UTT -1240-S	3-3/8"	75
12"	5"	2050	Rubber On Iron	15-1/2"	125- RIR -1250-S	125- RIT -1250-S	3-3/8"	90
		6000	Urethane on Iron	15-1/2"	125- UIR -1250-S	125- UIT -1250-S	3-3/8"	90
		6500	Ultra Thick Urethane	15-1/2"	125- UTR -1250-S	125- UTT -1250-S	3-3/8"	78
12"	6"	7500	Urethane on Iron	15-1/2"	125- UIR -1260-S	125- UIT -1260-S	3-3/8"	95
		10000	Cast Iron	15-1/2"	125- CIR -1260-S	125- CIT -1260-S	3-3/8"	130
14"	4"	6200	Ultra Thick Urethane	18"	125- UTR -1440-S	125- UTT -1440-S	3-11/16"	90
14"	5"	7600	Ultra Thick Urethane	18"	125- UTR -1450-S	125- UTT -1450-S	3-11/16"	85
14"	6"	7800	Urethane on Iron	18"	125- UIR -1460-S	125- UIT -1460-S	3-11/16"	120
		9000	Ultra Thick Urethane	18"	125- UTR -1460-S	125- UTT -1460-S	3-11/16"	140
16"	4"	2050	Rubber On Iron	19"	125- RIR -1640-S	125- RIT -1640-S	3-9/16"	130
		6000	Urethane on Iron	19"	125- UIR -1640-S	125- UIT -1640-S	3-9/16"	130
		7100	Ultra Thick Urethane	19"	125- UTR -1640-S	125- UTT -1640-S	3-9/16"	97
16"	5"	2570	Rubber On Iron	19"	125- RIR -1650-S	125- RIT -1650-S	3-9/16"	140
		8400	Urethane on Iron	19"	125- UIR -1650-S	125- UIT -1650-S	3-9/16"	140
		8800	Ultra Thick Urethane	19"	125- UTR -1650-S	125- UTT -1650-S	3-9/16"	130
18"	5"	2800	Rubber On Iron	22"	125- RIR -1850-S	125- RIT -1850-S	4-1/4"	150
		8600	Urethane on Iron	22"	125- UIR -1850-S	125- UIT -1850-S	4-1/4"	138
20"	5"	2900	Rubber On Iron	23"	125- RIR -2050-S	125- RIT -2050-S	4-1/4"	155
		9000	Urethane on Iron	23"	125- UIR -2050-S	125- UIT -2050-S	4-1/4"	149

To order a rigid caster, change the "S" to "R" in the model number. For example: "125-**CIR**-0840-R". To order rig only, omit the blue letters. For example: "125-0840-S". Dimensions shown are nominal. If precise dimensions are required, consult your RWM representative. For approximate weight of our rigid casters, deduct 12.5 pounds per item.