

The VersaTrac 27® Series Casters provide solutions to a wide range of institutional caster and industrial caster wheel applications. This light medium duty caster is available in multiple styles and sizes. It is offered in numerous top plates and stem choices and is available with nine standard wheel combinations. The VersaTrac 27® Series Caster is a durable and reliable caster featuring extra thick material in the top plate, yoke and raceways. The VersaTrac 27® Caster is heat treated for extended service life and comes standard with a metal dust shield. This light medium duty caster series provides the ultimate in value at very competitive prices.



27-RPB-0412-S-TG

FEATURES

Swivel Section	Two complete 2.75 mm shielded heat treated raceways, which prevents brinelling, provides improved swivel action and extends service life.
Kingpin	1/2" diameter kingpin for increased swivel strength
Capacity	Up to 300 lbs.
Axle	3/8" diameter with lock nut
Finish	Zinc plated to protect against corrosion
Wheels	A wide variety of 3" through 5" diameter available with either roller, ball, celcon, oilite or plain bearings
Mounting Plate Size	Swivel: 3.5 mm x 2-5/8" x 3-3/4" Rigid: 2.75 mm x 2-5/8" x 3-3/4"
Bolt Hole Spacing	1-3/4" x 2-7/8"
Mounting Bolt Diameter	5/16"

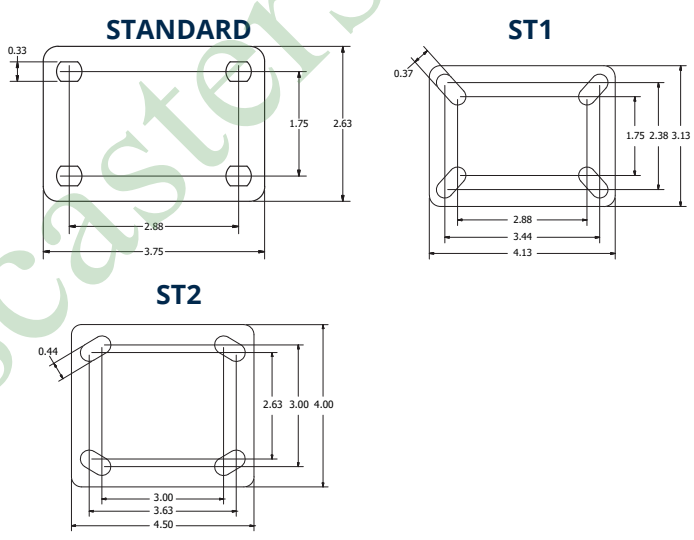

RACEWAY









APPLICATIONS

General industry	Bins and cases
Medical equipment	Racks and tables
Laboratory	Commercial appliances
Residential	Retail fixtures
Industrial caster and manufacturing applications	Display stands
Food service and processing equipment	Business machines and equipment
Carts and dollies	

OPTIONS

BRAKES	
ICWB	Field Installable Face Contact Brake*
TLB	Total Lock Brake*
WB	Side Wheel Brake*
TG	Thread Guard

*Brakes available for swivel casters only.

Wheel Diameter	Wheel Width	Wheel Type  lbs.	Capacity	Overall Height 	Swivel Caster Model Numbers			Swivel Lead 	Approx Weight  lbs.
					 Roller Bearing	 Ball Bearing	 Plain Bearing		
3"	1-1/4"	Soft Rubber	150	4-1/4"			27-SRO-0312-S	1-1/4"	1.8
		Performance TPR	190	4-1/4"		27-RPB-0312-S	27-RPC-0312-S	1-1/4"	1.7
		Urethane Polypropylene	225	4-1/4"		27-UPB-0312-S	27-UPC-0312-S	1-1/4"	1.8
		Hard Rubber	250	4-1/4"			27-HRO-0312-S	1-1/4"	1.8
		Phenolic	250	4-1/4"		27-DUB-0312-S	27-DUC-0312-S	1-1/4"	1.7
		Polyolefin	250	4-1/4"		27-POB-0312-S	27-POP-0312-S	1-1/4"	1.5
		Cast Iron	300	4-1/4"			27-CIP-0312-S	1-1/4"	2.8
		High-Temp. Nylon	300	4-1/4"			27-HNP-0312-S	1-1/4"	1.7
3-1/2"	1-1/4"	Soft Rubber	150	4-3/4"			27-SRO-3512-S	1-5/16"	2
		Performance TPR	200	4-3/4"		27-RPB-3512-R	27-RPC-3512-S	1-5/16"	1.9
		Signature	225	4-3/4"		27-SWB-3512-S		1-5/16"	1.9
		Hard Rubber	250	4-3/4"			27-HRO-3512-S	1-5/16"	2
		Urethane Polypropylene	250	4-3/4"		27-UPB-3512-S	27-UPC-3512-S	1-5/16"	2
		Phenolic	275	4-3/4"		27-DUB-3512-S	27-DUC-3512-S	1-5/16"	1.9
		Polyolefin	275	4-3/4"		27-POB-3512-S	27-POP-3512-S	1-5/16"	1.7
4"	1-1/4"	Soft Rubber	180	5-1/4"			27-SRO-0412-S	1-5/16"	2.2
		Elastic Rubber	250	5-1/4"	27-EPR-0412-S			1-5/16"	2
		Signature	250	5-1/4"		27-SWB-0412-S		1-5/16"	2
		Hard Rubber	260	5-1/4"			27-HRO-0412-S	1-5/16"	2.2
		Performance TPR	275	5-1/4"		27-RPB-0412-S	27-RPC-0412-S	1-5/16"	1.9
		Urethane Polypropylene	275	5-1/4"		27-UPB-0412-S	27-UPC-0412-S	1-5/16"	2
		Cast Iron	300	5-1/4"			27-CIP-0412-S	1-5/16"	3.3
		High-Temp. Nylon	300	5-1/4"			27-HNP-0412-S	1-5/16"	1.8
		Phenolic	300	5-1/4"		27-DUB-0412-S	27-DUC-0412-S	1-5/16"	2.1
		Polyolefin	300	5-1/4"		27-POB-0412-S	27-POP-0412-S	1-5/16"	1.6
5"	1-1/4"	Soft Rubber	200	6-5/16"			27-SRO-0512-S	1-5/16"	2.7
		Signature	250	6-5/16"		27-SWB-0512-S		1-5/16"	2.1
		Hard Rubber	280	6-5/16"			27-HRO-0512-S	1-5/16"	2.7
		Cast Iron	300	6-5/16"			27-CIP-0512-S	1-5/16"	3.9
		Elastic Rubber	300	6-5/16"	27-EPR-0512-S			1-5/16"	2.2
		High-Temp. Nylon	300	6-5/16"			27-HNP-0512-S	1-5/16"	2
		Performance TPR	300	6-5/16"		27-RPB-0512-S	27-RPC-0512-S	1-5/16"	2.1
		Phenolic	300	6-5/16"		27-DUB-0512-S	27-DUC-0512-S	1-5/16"	2.2
		Polyolefin	300	6-5/16"		27-POB-0512-S	27-POP-0512-S	1-5/16"	1.8
		Urethane Polypropylene	300	6-5/16"		27-UPB-0512-S	27-UPC-0512-S	1-5/16"	2.2

To order a rigid caster, change the "S" to "R" in the model number. For example, 27-UPB-0512-R. To order the rig only, omit the blue letters, for example 27-0512-S. Note: (1.) For weight of Total Lock Caster add .24 pounds. (2.) For weight of Rigid Caster deduct .7 pounds. (3.) Total Lock Wheel Brake should not be used on hard wheels. For best performance, use only on soft wheel material. Dimensions shown are nominal. If precise dimensions are required, please consult the factory. Many stems and hollow kingpin sizes are available. Contact factory for more information.